

moveXX

driven by brain power



DATASHEET
Movexx T1000-RZ



Specifications T1000-RZ

Frame	Steel, powder coated
Drive	24V DC, 300W, 100 rpm (inc.parking brake)
Weight	154 kg
Weight trailer	Max. 1000 kg
Battery	Exchangable batterypack
Speed	Max. 3,8 km/h, freely programmable
Drive wheels	Vulcolan ø200x55 mm
Width	638mm
Length	1230mm
Adze height	1269mm
Folded	
Noise level	63,8 dB
To use from	-40 °C / 70 °C
Protection class	Machine IP44
Lifting capacity	600 kg

Dimensions T1000-RZ

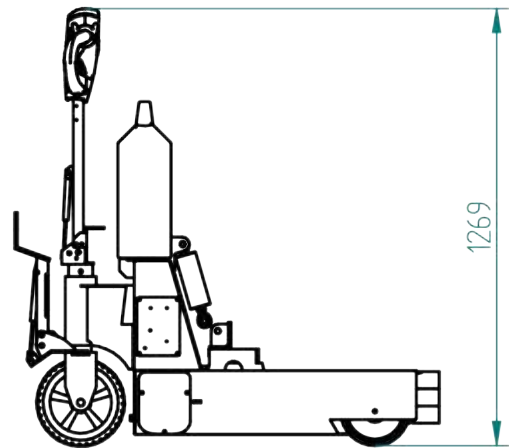
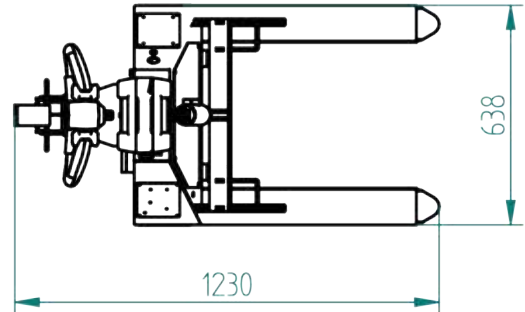

Pulling power T1000-RZ (in kg)

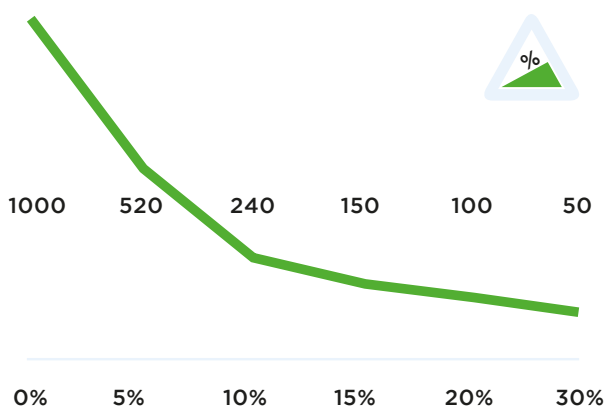

**Measured with a trolley with 2 swivelwheels and 2 fixed castors. Wheel diameter: 160mm*

Standard T1000-RZ



Standard parts T1000-RZ

Charger 24V 5A incl. charging cable



Item number:
OPT0009

Accu maintenance-free AGM 24V-20Ah, 6018



Item number:
OPT0110-RAL6018

Drive wheel Ø200 B50 d20 mm



Item number:
M0340

Adjustable tillerhead



Item number:
Standardpart 1

Safety switch



Item number:
Standardpart 2

2 programmable speeds



Item number:
Standardpart 3

Standard parts T1000-RZ

Motor 300W 100RPM with brake



Item number:
M1033

LED battery indicator LBF318-24V



Item number:
M0123

Options T1000-RZ



**SURCHARGE Engine
420W-140RPM+BRA-
KE**

Article number:
OPT0030



**Battery Lithium-Li-
FePO4 25,6V-36Ah
GREEN**

Article number:
OPT0106



**Battery Lith. instead
Battery AGM GREEN**

Including charger

Article number:
OPT0107



**Accu mainte-
nance-free AGM
24V-20Ah, 6018**

Article number:
OPT0110-RAL6018



**SURCHARGE wheel
full rubber non-mar-
king**

Article number:
OPT0162



**Horn with controll on
bellybutton**

Article number:
OPT0049



Horn 103 dB

Article number:
OPT0059



**Emergency stop
complete**

Article number:
OPT0063



Strobelight

Article number:
OPT0065



**Bellybutton 2-step
reset**

*After bellybutton use off/
on switch is necessary*

Article number:
OPT0168



**Acoustic signal while
driving**

Article number:
OPT0253



**Acoustic signal dri-
ving backwards**

Article number:
OPT0254

Options T1000-RZ



On/off switch machine

Article number:
OPT0016



Document holder with clip

Article number:
OPT0053



hour counter complete

Article number:
OPT0056



Horn 90dB

Article number:
OPT0057



Antistatic strip

Article number:
OPT0058



Code lock

Article number:
OPT0068



Ignition key equal key

Article number:
OPT0146



Ignition key under larger tiller head

Unequal key. Only with OPT0171

Article number:
OPT0147



Ignition key under larger tiller head

Equal key. Only with OPT0171

Article number:
OPT0148



Drive protection

Tiller head in straight up position

Article number:
OPT0153



Customized programming

Article number:
OPT0170



Larger Tiller-Head

With 6 switch positions

Article number:
OPT0171

Options T1000-RZ



Programmer for Ital-sea

Article number:
D0003



Charger unit for 1 AGM battery

Article number:
OPT0015



Charging Station for 1 Lithium battery

Article number:
OPT0023



Charging station for 5 Lithium batteries

Article number:
OPT0029



Charging station for 5 batteries

Article number:
OPT0039



U-Frame for waste container 1000/1100L

Article number:
OPT0088



Charging Station for 6 AGM Batteries

Article number:
OPT0115



Locking module charging Station 6 units

Locking module charging Station with 6 units

Article number:
OPT0152



Trolley for Milkrun machines

Article number:
OPT0179



Surcharge single charging station

Article number:
OPT0261



Hook function RZ&R-ZS

Inside use only. Max 7 km/h

Article number:
OPT0194



Jacket Movexx size M

Article number:
OPT0197

Options T1000-RZ

Jacket Movexx size L



Article number:
OPT0198

Jacket Movexx size
XL



Article number:
OPT0199

Movexx Parking label



Article number:
OPT0245



Movexx International B.V.

Wiltonstraat 61-63

3905 KW Veenendaal

Tel +31 (0)318 51.99.00

Fax +31 (0)318 50.80.20

E-mail info@movexx.nl